

Metric Dimensions in mm
(shown in parentheses)

ORDERING INFORMATION

Voltage*	Continuous Current	Model
120V	3 Amps	IE-103
120V	5 Amps	IE-105
120V	10 Amps	IE-110
120V	20 Amps	IE-120
240V	3 Amps	IE-203
240V	5 Amps	IE-205
240V	10 Amps	IE-210
240V	20 Amps	IE-220

* All voltage configurations are single phase—2 wire + gnd.

CONNECTION DIAGRAM

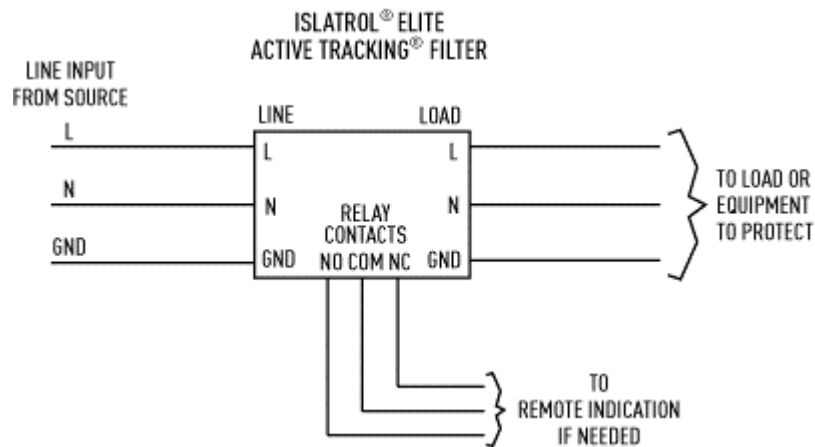

SYSTEM DESIGN

